

Pneumatic Brakes

Mistral Brakes

Modular design permits variable tensioning capacities!

Wichita Clutch's Mistral pneumatic tension brakes are ideally suited to the needs of the corrugating market for which it was originally designed. It is also a versatile product which is finding favor in additional tensioning applications. Wichita Clutch designers and engineers consulted extensively with mill roll stand manufacturers and users to offer a tension brake ideally suited to the needs of this particular market. The result is a compact, high performance, versatile brake capable of handling the tensioning needs of the latest machine designs, as well as existing equipment. The Mistral paves the way for increasing line speeds by 5.4 feet/sec. from 810 feet/min. (or slower) to 1,140 feet/min.

Varying number of actuators provide optimum tension control

Each brake may be specified with a varying number of pneumatic actuators, allowing precise selection of brake torque capacity for optimum tension control.

Compact Design

Mistral brakes are compact at only 11.6" or 16.1" in diameter. Their size facilitates the pickup of small, part reels



used in short batch runs. For automatic reel loading machines, Mistral offers optional infrared and speed sensor installation within the brake. And their modern, industrial styling enhances the appearance of any machine on which they are used.

Easy Access with Removable Cover Panel

By removing just three cap screws, the Mistral's front cover can be detached for easy and fast access to internal parts. Cover removal automatically disconnects both air and electricity.

Performance Curve

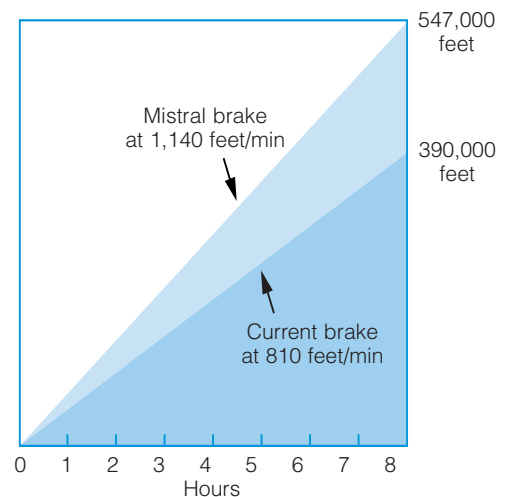

Mounting Ease

Three bolts mount the brake to the arm of the mill roll stand or machine frame and an optional pilot location makes fitting to both new and existing machines a simple operation.



Wear Indicator

A brake wear indicator, which is conveniently located for easy visual inspection, means no down time to check remaining friction material life.

Easy Connection

Air and electrical connections are easily accessible for fast, simple installation and maintenance.

Safety

Mistral's integral guarding eliminates the cost and effort of installing external guards.

Operator safety is further enhanced by automatic air and electric disconnects when the front cover is removed.

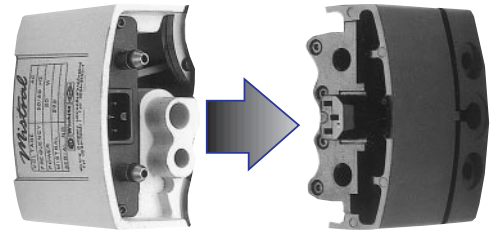

Integral Cooling

A rugged, high performance, low energy usage fan is housed within the brake for high heat dissipation — a must for increased productivity through controlled tension at many roll speeds.

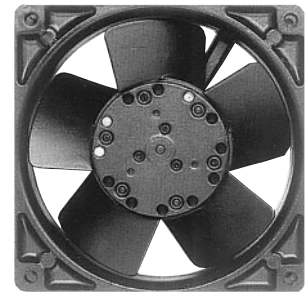

Fan and Connection Data

Model	Fan Voltages	Fan Power	Electric	Pneum.
150	220VAC 50/60 Hz	11W	M16	1/8 BSP
	110VAC 50/60 Hz		PG9	1/8 BSP
	24VDC		3/8 NPT	1/8 NPT
200	220VAC 50/60 Hz	20W	M16	1/8 BSP
	110VAC 50/60 Hz		PG9	1/8 BSP
	24VDC		3/8 NPT	1/8 NPT
280	220VAC 50/60 Hz	18W	M16	1/8 BSP
	110VAC 50/60 Hz		PG9	1/8 BSP
	24VDC		3/8 NPT	1/8 NPT

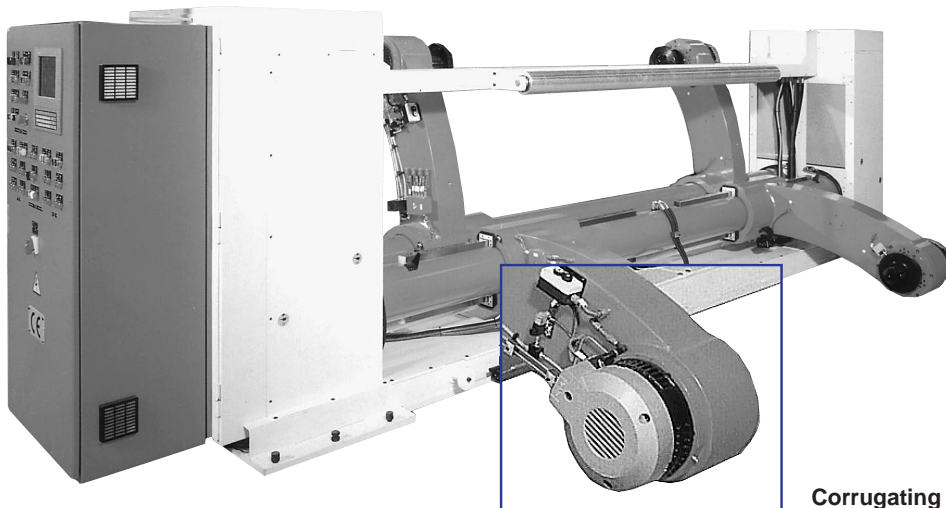

Corrugating Press Installation

Pneumatic Brakes

Mistral Brakes

Specifications

Model	Dynamic Slipping Torque Capacity				Heat Transfer Capacity with fan				Maximum Speed (rev./min.)	Inertia of Rotating Parts		Weight				Fan Power Rating (W)
	Air Pressure (lb.in.)				Continuous :30 On/:30 Off Operation					Wr ² (lb.ft. ²)	J=mr ² (kgm ²)	Total Brake		Rotating Parts		
	min* 3 psi	max. 80 psi	min* 0.2 BAR	max. 5.5 BAR	(hp)	(kW)	(hp)	(kW)				(lb.)	(kg)	(lb.)	(kg)	
150/2/LC**	12	440	1.3	50	1.9	1.4			3520	.097	.004	35	15.9	6.5	2.9	11
150/2**	22	665	2.5	75	1.9	1.4			3520	.097	.004	35	15.9	6.5	2.9	11
150/4/LC**	25	880	2.8	99	1.9	1.4			3520	.097	.004	35	15.9	6.5	2.9	11
150/4**	45	1330	5	150	1.9	1.4			3520	.097	.004	35	15.9	6.5	2.9	11
200/2/LC	62	1770	7	200	3.2	2.4	3.5	2.6	2860	0.40	0.017	77	35	9.92	4.5	20
200/2	97	2655	11	300	3.2	2.4	3.5	2.6	2860	0.40	0.017	77	35	9.92	4.5	20
200/4/LC	124	3540	14	400	3.2	2.4	3.5	2.6	2860	0.40	0.017	77	35	9.92	4.5	20
200/4	195	5310	22	600	3.2	2.4	3.5	2.6	2860	0.40	0.017	77	35	9.92	4.5	20
200/6/LC	195	5310	22	600	3.2	2.4	3.5	2.6	2860	0.40	0.017	77	35	9.92	4.5	20
200/6	292	7965	33	900	3.2	2.4	3.5	2.6	2860	0.40	0.017	77	35	9.92	4.5	20
280/3/LC	133	3540	14	400	6.4	4.8	7	5.2	2090	1.80	0.076	110	50	20.72	9.4	25
280/3	199	5310	21	600	6.4	4.8	7	5.2	2090	1.80	0.076	110	50	20.72	9.4	25
280/6/LC	265	7080	28	800	6.4	4.8	7	5.2	2090	1.80	0.076	110	50	20.72	9.4	25
280/6	399	10620	42	1200	6.4	4.8	7	5.2	2090	1.80	0.076	110	50	20.72	9.4	25
280/9/LC	399	10620	42	1200	6.4	4.8	7	5.2	2090	1.80	0.076	110	50	20.72	9.4	25
280/9	597	15930	63	1800	6.4	4.8	7	5.2	2090	1.80	0.076	110	50	20.72	9.4	25

* Lower minimum torques possible with appropriate control.

**Size 150 available with fan, consult factory

Dimensions

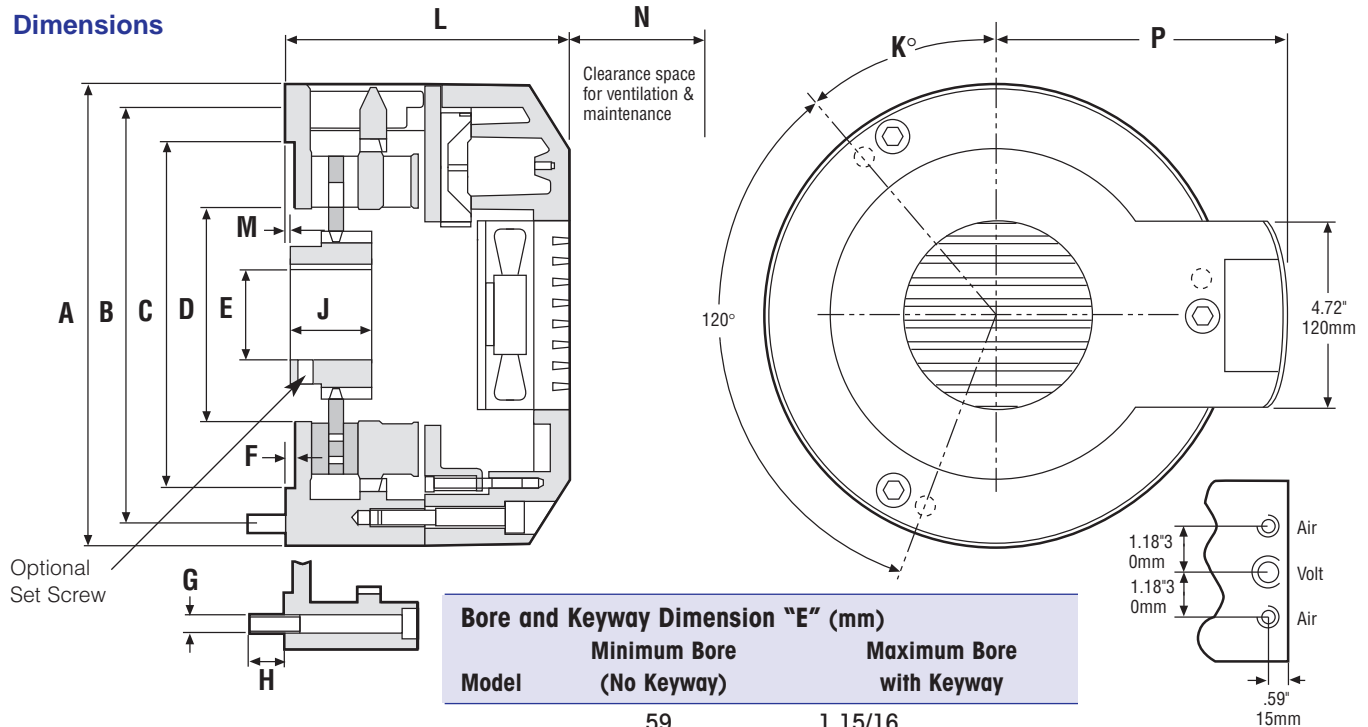

Bore and Keyway Dimension "E" (mm)			
Model	Minimum Bore (No Keyway)	Maximum Bore with Keyway	
150	.59 (15)	1 15/16 (50)	-
200	1.00 (25)	2 3/8 (60)	5/8 x 7/32 (18 x 4.4)
280	1.00 (25)	2 5/8 (65)	3/4 x 1/4 (18 x 4.4)

Model	A	B (H.C.)	F	G	H	J	K (DEG)	L	M	N	P
150	8.82 (224)	7.99 (203)	.16 (4)	M8	.71 (18)	1.97 (50)	55° (55°)	5.20 (132)	0	1.38 (35)	N/A
150 Dual	8.82 (224)	7.99 (203)	.16 (4)	M8	.71 (18)	3.94 (100)	55° (55°)	7.17 (182)	0	1.38 (35)	N/A
200	11.61 (295)	10.236 (260)	.24 (6)	1/2 (M12)	.98 (25)	1.97 (50)	40° (40°)	7.01 (178)	N/A (N/A)	2.76 (70)	7.19 (182.5)
280	16.14 (410)	13.976 (355)	0 (0)	5/8 (M16)	1.18 (30)	2.36 (60)	20° (20°)	7.56 (192)	0.37 (9.5)	3.15 (80)	9.47 (240.5)

Model	Mounting Pilot	Mounting Bolts Qty. and Size
150	Dim. "C" 7.48 (190)	(4 x M8 x 18mm)
200	Dim. "C" 8.661 +.003 / -.000 (220 +.08 / -.00)	3 @ 1/2-13 UNC (3 @ M12 x 1-3/4)
280	Dim. "D" 6.890 +.003 / -.000 (175 +.08 / -.00)	3 @ 5/8-11 UNC (3 @ M16 x 2)

Actuator/Inlet (see previous page for details)				
Model	No. of Actuators	No. of Air Inlets	No. of Actuators Per Air Inlets	
			AA	BB
150/2	2	1	0	2
150/4	4	2	2	2
200/2	2	2	2	0
200/4	4	2	2	2
200/6	6	2	2	4
280/3	3	2	3	0
280/6	6	2	3	3
280/9	9	2	3	6